

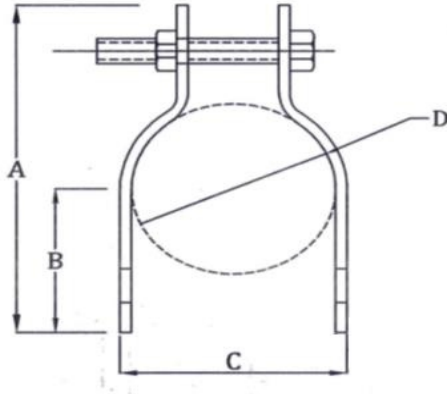

STRUT CLAMP



FEATURES AND BENEFITS.

Description:-	<ul style="list-style-type: none"> * Two-part clamp. * For direct fixing of pipes to Strut Rail. * Both ends suitable for locating into Strut Rail.
Material:-	Steel, other materials on request.
Special:-	<ul style="list-style-type: none"> * Electro galvanized as per ASTM B 633. * Galvanized as per ASTM A 123 / A 123M. * Designed to meet MSS Standard SP-58, type 24 and SP-69.

Product Code	Nominal Pipe Size		Pipe OD (D) mm	(A) mm	(B) mm	(C) mm	Fasteners Size	Box Qty.
	In.	mm						
HGEPSCP022	½"	DN15	21.3	50.5	14.2	25	M 6 X 25	500
HGEPSCP027	¾"	DN20	26.7	57.1	17.5	30	M 6 X 25	400
HGEPSCP034	1"	DN25	33.4	63.8	20.6	38	M 6 X 25	350
HGEPSCP042	1 ¼"	DN32	42.1	76.2	25.4	46	M 6 X 25	300
HGEPSCP048	1 ½"	DN40	48.2	81.5	28.4	52	M 6 X 25	250
HGEPSCP060	2"	DN50	60.3	95.8	34.8	65	M 8 X 40	200
HGEPSCP073	2 ½"	DN65	73	108.7	41.1	78	M 8 X 40	150
HGEPSCP090	3"	DN80	88.9	128.3	50.8	94	M 8 X 40	100
HGEPSCP114	4"	DN100	114.3	153.7	63.5	120	M 8 X 40	75
HGEPSCP168	6"	DN150	168.3	220	106	172	M 8 X 40	50

NOTE:- 1. OTHER DIMENSIONS AVAILABLE ON REQUEST.

2. a. EP - MICRONS : 8μ - 15μ
- b. HDG - MICRONS : 70μ - 95μ

