

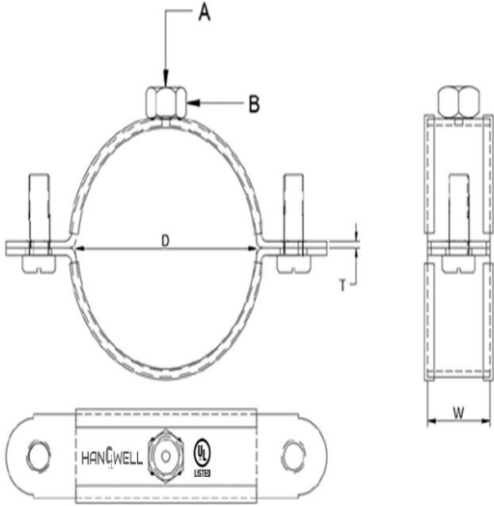

UL LISTED NUT CLAMP WITH/WITHOUT RUBBER



FEATURES AND BENEFITS.

Coating Specification:	* Minimum 13+ micron Electro-galvanized zinc plating.
Dimensional Tolerance :	* All Dimensions are as per Table LNC-01 unless otherwise specified. * For dimensions not specified: $\pm 3\%$.
Material Specification:	M.S (Mild steel) IS:513 / IS 1079 / IS 2062 / ASTM A36 / ASTM A1008 / ASTM A1011 and all equivalent ASTM and EN specifications.
Assembly Specifications:	* Can be Provided with our without Rubber Lining.

Table No LNC-01. Nut Clamp With Rubber / Without Rubber Specification

Product Code	NPS	Rod Size mm (A)	Hex Nut size (B)	Lining Composition (EPDM Rubber)	Side Screw Size	Surface Coating Thickness	Maximum Load (N)
FG-LNC-05	1/2"	M10	M10	Hardness : Shore A 60-75	M6 X 18mm	13+ microns	3336
FG-LNC-07	3/4"	M10	M10	Hardness : Shore A 60-75	M6 X 18mm	13+ microns	3336
FG-LNC-10	1"	M10	M10	Hardness : Shore A 60-75	M6 X 18mm	13+ microns	3336
FG-LNC-15	1 1/2"	M10	M10	Hardness : Shore A 60-75	M6 X 18mm	13+ microns	3336
FG-LNC-20	2"	M10	M10	Hardness : Shore A 60-75	M6 X 18mm	13+ microns	3336
FG-LNC-25	2 1/2"	M10	M10	Hardness : Shore A 60-75	M6 X 18mm	13+ microns	3781
FG-LNC-30	3"	M10	M10	Hardness : Shore A 60-75	M6 X 18mm	13+ microns	4460
FG-LNC-38	110 MM	M10	M10	Hardness : Shore A 60-75	M6 X 18mm	13+ microns	6672
FG-LNC-40	4"	M10	M10	Hardness : Shore A 60-75	M6 X 18mm	13+ microns	6672

NOTE:- 1. CAN BE PROVIDED WITH OR WITHOUT RUBBER.
2. CAN BE PROVIDED WITH OR WITHOUT TOP NUT.

