

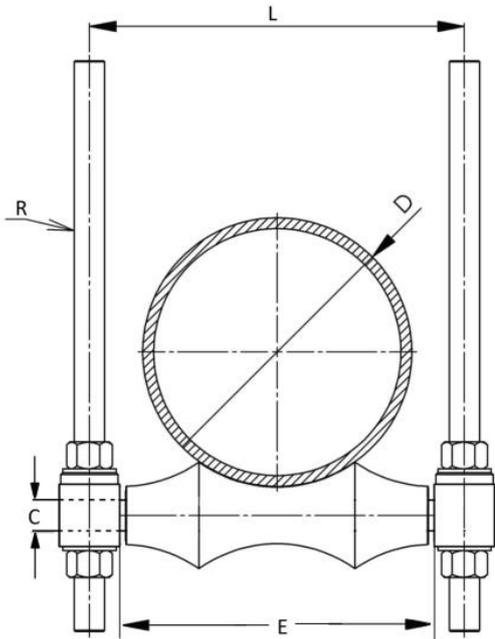

PIPE ROLLER



FEATURES AND BENEFITS.

| | |
|----------------------|---|
| Description:- | <ul style="list-style-type: none"> * For support of pipes to provide axial movement. * Multiple pipe installations possible by using two rollers. * Versatile design permits axial movement of pipe due to expansion and contraction. * Standard installation would support a single pipe and design permits installation of two pipes in double banking arrangement. In such cases ensure that the total weight of the installation is less than the maximum load of the roller as mentioned in the table. * Insulation protection products such as Rubber Support Inserts, Insulation Protection Shields and Pipe Covering Protection Saddles can be used with Pipe Rollers. |
| Material:- | <p>Bracket : Steel Roller : Solid steel shaft</p> |
| Special:- | <ul style="list-style-type: none"> * Galvanized as per ASTM B 633. * Galvanized as per ASTM A 123 / A 123M. * Designed to meet MSS Standard SP-58-2002, type 44 and SP-69. |

| Product Code | Nominal Pipe Size | | Pipe OD (D) mm | Dimensions (mm) | | | Max Load (N) |
|--------------|-------------------|-------|-------------------|-----------------|-----------|-----|-----------------|
| | In. | mm | | E | CXL | R | |
| HGEPPR060 | 2" | DN50 | 60.3 | 70 | M12 x 115 | M12 | 3500 |
| HGEPPR073 | 2 ½" | DN65 | 73 | 83 | M12 x 125 | M12 | 3500 |
| HGEPPR090 | 3" | DN80 | 88.9 | 99 | M12 x 145 | M12 | 3500 |
| HGEPPR101 | 3 ½" | DN90 | 101.6 | 112 | M12 x 160 | M12 | 3500 |
| HGEPPR114 | 4" | DN100 | 114.3 | 125 | M12 x 175 | M12 | 5000 |
| HGEPPR141 | 5" | DN125 | 141.3 | 152 | M12 x 200 | M12 | 5000 |
| HGEPPR168 | 6" | DN150 | 168.3 | 179 | M20 x 245 | M16 | 5000 |
| HGEPPR219 | 8" | DN200 | 219.1 | 231 | M24 x 305 | M16 | 12500 |
| HGEPPR273 | 10" | DN250 | 273 | 285 | M24 x 365 | M20 | 12500 |
| HGEPPR323 | 12" | DN300 | 323.8 | 336 | M24 x 425 | M20 | 15000 |
| HGEPPR356 | 14" | DN350 | 355.6 | 368 | M24 x 460 | M24 | 15000 |
| HGEPPR406 | 16" | DN400 | 406.4 | 419 | M24 x 515 | M24 | 20000 |
| HGEPPR457 | 18" | DN450 | 457.2 | 470 | M33 x 580 | M32 | 35000 |
| HGEPPR508 | 20" | DN500 | 508.2 | 520 | M33 x 630 | M32 | 35000 |
| HGEPPR610 | 24" | DN600 | 609.6 | 626 | M52 x 780 | M36 | 50000 |
| HGEPPR661 | 26" | DN650 | 661 | 679 | M52 x 845 | M36 | 50000 |
| HGEPPR712 | 28" | DN700 | 712 | 732 | M52 x 895 | M36 | 50000 |
| HGEPPR755 | 30" | DN750 | 755 | 778 | M52 x 940 | M36 | 50000 |

NOTE:- 1. CUSTOMIZED DIMENSIONS AVAILABLE ON REQUEST.

2. a. EP - MICRONS : 8μ - 15μ

b. HDG - MICRONS : 70μ - 95μ

