

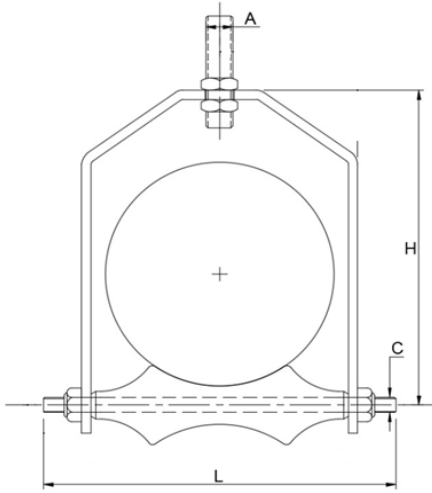

ADJUSTABLE ROLLER HANGER



FEATURES AND BENEFITS.

Description:-	<ul style="list-style-type: none"> * For support of pipe where horizontal movement due to expansion and contraction may occur. * Vertical adjustment up to 6" is possible.
Material:-	<ul style="list-style-type: none"> Bracket : Steel Roller : Solid steel shaft
Special:-	<ul style="list-style-type: none"> * Electro galvanized as per ASTM B 633. * Galvanized as per ASTM A 123 / A 123M. * Designed to meet MSS Standard SP-58-2002, type 43 and SP-69.

Product Code	Nominal Pipe Size		Pipe OD (D) mm	Dimensions (mm)			Max Load (N)
	In.	mm		A	CXL	H	
HGEPARH060	2"	DN50	60.3	M12	M12 X 115	105	2100
HGEPARH073	2 ½"	DN65	73	M12	M12 X 125	125	2100
HGEPARH090	3"	DN80	88.9	M12	M12 X 145	140	2100
HGEPARH101	3 ½"	DN90	101.6	M16	M12 X 160	155	2100
HGEPARH114	4"	DN100	114.3	M16	M12 X 175	170	2900
HGEPARH141	5"	DN125	141.3	M20	M12 X 200	200	5500
HGEPARH168	6"	DN150	168.3	M20	M20 X 245	230	5500
HGEPARH219	8"	DN200	219.1	M20	M24 X 305	290	6000
HGEPARH273	10"	DN250	273	M24	M24 X 365	350	6000
HGEPARH323	12"	DN300	323.8	M24	M24 X 425	400	7500
HGEPARH356	14"	DN350	355.6	M24	M24 X 460	445	7500
HGEPARH406	16"	DN400	406.4	M24	M24 X 515	500	7500
HGEPARH457	18"	DN450	457.2	M30	M33 X 580	555	7500
HGEPARH508	20"	DN500	508.2	M30	M33 X 630	610	9000
HGEPARH610	24"	DN600	609.6	M30	M52 X 780	725	11000
HGEPARH661	26"	DN650	661	M36	M52 X 845	785	11000
HGEPARH712	28"	DN700	712	M36	M52 X 895	840	11000
HGEPARH755	30"	DN750	755	M36	M52 X 940	885	11000

NOTE:- 1. OTHER DIMENSIONS AVAILABLE ON REQUEST.

2. a. EP - MICRONS : 8μ - 15μ

b. HDG - MICRONS : 70μ - 95μ

