

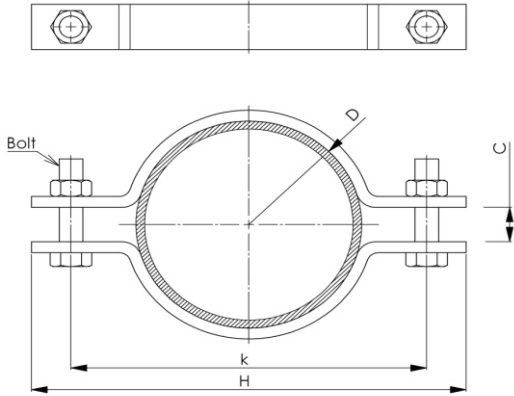

TWO BOLT CLAMP



FEATURES AND BENEFITS.

Description:-	<ul style="list-style-type: none"> * Designed to act as a horizontal support for heavier pipes. * Two bolt arrangement provides sturdier support.
Material:-	Steel, other materials on request.
Special:-	<ul style="list-style-type: none"> * Electro galvanized as per ASTM B 633. * Galvanized as per ASTM A 123 / A 123M. * Designed to meet MSS Standard SP-58-2002, type 8 and SP-69.

Product Code	Nominal Pipe Size		Pipe OD (D) mm	Total length (H) mm	Length Between Bolts(k) mm	Gap (C) mm	Bolt Size mm	Max Load (N)	Box Quantity
	In.	mm							
HGEPTBC022	½"	DN15	21.3	97	68	12	M10	1700	50
HGEPTBC027	¾"	DN20	26.7	105	76	12	M10	1700	50
HGEPTBC034	1"	DN25	33.4	113	84	12	M10	1700	50
HGEPTBC042	1 ¼"	DN32	42.1	121	92	12	M10	1700	50
HGEPTBC048	1 ½"	DN40	48.2	127	98	12	M10	1700	50
HGEPTBC060	2"	DN50	60.3	156	116	16	M10	1700	40
HGEPTBC073	2 ½"	DN65	73	182	142	16	M12	4000	40
HGEPTBC090	3"	DN80	88.9	196	156	16	M12	4000	30
HGEPTBC101	3 ½"	DN90	101	208	168	16	M12	4000	30
HGEPTBC114	4"	DN100	114.3	220	180	19	M12	4000	20
HGEPTBC141	5"	DN125	141.3	252	214	19	M16	6000	15
HGEPTBC168	6"	DN150	168.3	290	242	22	M16	6000	10
HGEPTBC219	8"	DN200	219.1	352	302	25	M16	11000	5
HGEPTBC273	10"	DN250	273.1	406	358	25	M16	12000	1
HGEPTBC323	12"	DN300	323.8	490	430	25	M20	15000	1
HGEPTBC355	14"	DN350	355.6	546	480	28	M20	15000	1
HGEPTBC406	16"	DN400	406.4	597	532	28	M20	22000	1
HGEPTBC457	18"	DN450	457.2	686	610	32	M20	20000	1
HGEPTBC508	20"	DN500	508	776	680	35	M20	22000	1
HGEPTBC610	24"	DN600	609.6	876	780	42	M20	22000	1

NOTE:- 1. CUSTOMIZED DIMENSIONS AVAILABLE ON REQUEST.

2. a. EP - MICRONS : 8μ - 15μ
- b. HDG - MICRONS : 70μ - 95μ

