

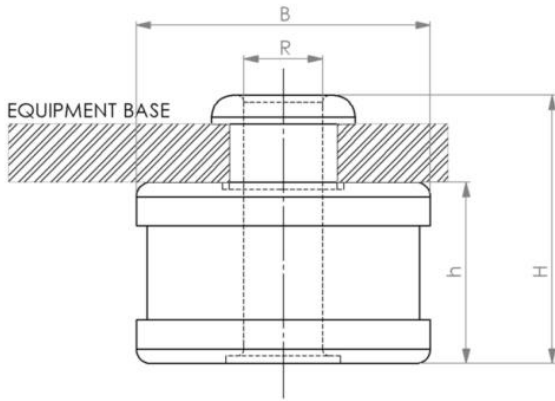

## DOCT MOUNT



### FEATURES AND BENEFITS.

**Description:-**

- \* Duct Hanger consist of a resilient rubber mount held between two plated steel caps.
- \* For uniform distribution of load. If has an integral extended rubber sleeve which prevents direct.
- \* Metal-to-metal contact, thereby minimizing transmission of noise and vibration.

### TYPICAL APPLICATIONS

**SUSPENSION OF**

- \* Fan Coil Units
- \* Pipes
- \* Ducts
- \* Brackets
- \* Light Weight Equipment

**FLOOR MOUNTING OF**  
(using rubber element only)

- \* Refrigerators
- \* Domestic Appliances
- \* Industrial Equipments

Product Code	B mm	H mm	h mm	R mm	Deflection mm	Max Load (N)
HGDM9	41	37	25	M10	4	900
HGDM6	32	27	19	M10	4	600

- NOTE:-** 1. DUE TO POLICY OF CONTINUAL IMPROVEMENT, THE SPECIFICATIONS ARE SUBJECT TO CHANGE WITHOUT PRIOR NOTICE.  
2. MEASUREMENTS ARE SUBJECT TO 5% TOLERANCE.  
3. TO ACHIEVE GOOD SOUND SUPPRESSIONS DO NOT OVER LOAD FITTING.

